

ELECTRICAL ENGINEERING DEPARTMENT

LABORATORY MANUAL
TRANSDUCERS LAB (EE 385)
for
B.E. III/IV I-SEM EIE



MUFFAKHAM JAH COLLEGE OF ENGINEERING & TECHNOLOGY

Banjara Hills Road No 3, Hyderabad- 34.

www.mjcollege.ac.in

WITH EFFECT FROM THE ACADEMIC YEAR 2012 - 2013

EE 385

TRANSDUCERS LAB

Instruction	3 Periods per week
Duration of University Examination	3 Hours
University Examination	50 Marks
Sessional	25 Marks

1. Measurement of speed by magnetic pickup
2. Measurement of temperature by (a) Thermistors (b) Thermocouple
3. Study and calibration of strain gauge
4. Measurement of speed and torque using Opto Electronic Sensor
5. Measurement of pressure by bellows
6. Measurement of Displacement by Capacitive pickup
7. Measurement of Displacement by (a) Piezoelectric pickup and
(b) Light dependent resistor
8. Level Measuring System
9. Study and Calibration of LVDT
10. Study and calibration of RTD
11. Measurement of displacement by inductive pickup

NOTE: ATLEAST 10 EXPERIMENTS SHOULD BE CONDUCTED IN THE SEMESTER

Index

S.No.	Name of the Experiment	Page No.
1	Measurement of Speed by Magnetic Pickup and Optoelectronic sensor.	1
2	Measurement of Temperature by a) Thermistor. b) Thermocouple.	5 7
3	Study and Calibration of Strain Gauge.	10
4	Measurement of Torque using Opto-electronic sensor.	15
5	Measurement of Pressure.	19
6	Measurement of Displacement by Capacitive pickup.	22
7	Measurement of Displacement by Light dependent resistor.	25
8	Level Measuring System.	28
9	Study and Calibration of LVDT.	33
10	Study and Calibration of RTD.	37
11	Measurement of displacement by Inductive pickup.	41

MEASUREMENT OF SPEED

Aim: - To study and calibrate speed measurement system using

- 1) Magnetic pickup.
- 2) Photo electric pickup.

Apparatus Required:-

Speed measurement experimental setup and analog tachometer.

Magnetic Pickup:-

This comes under Non-contact type of measurement of speed. The principle of variation of reluctance in the air gap as the shaft rotates is made use for the measurement of speed. As the toothed wheel attached to the shaft rotates variation of reluctance is obtained. This varies the flux, which in turn causes changes in the induced emf of a coil. It is fairly sinusoidal and the peak to peak is proportional to speed.

In this set up, toothed wheel is mounted on the motor shaft. The pickup consists of a coil wound around a permanent magnet. Certain air gap is maintained between the coils and the toothed wheel.

The magnetic field surrounding the coil is distorted by passing of a tooth, causing a pulse of output voltage in the coil. The RMS value of the output voltage increases with

- 1) Reduction of gap between rotor and pickup.
- 2) Increase of tooth size.
- 3) Increase in rotor speed.

The frequency of the output pulses is dependent on

- 1) Number of teeth.
- 2) Rotor speed.

Circuit Diagram:-

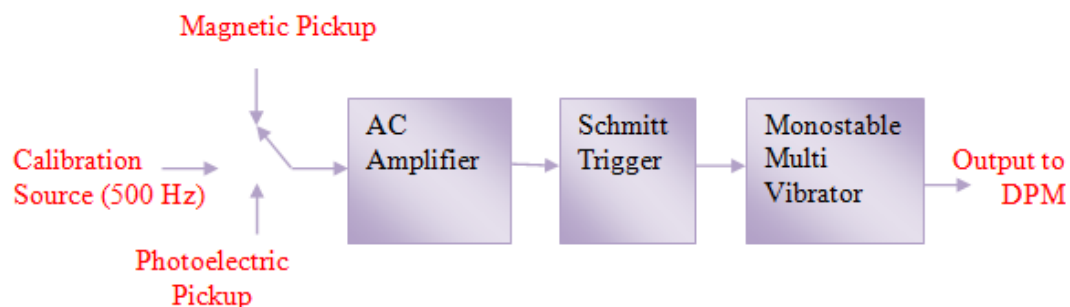

Figure: 1

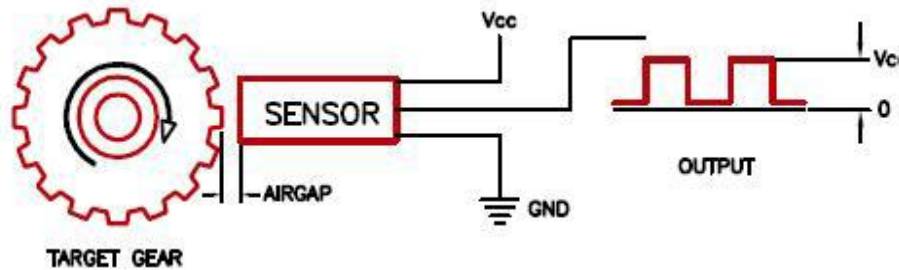

Figure: 2

Circuit Operation:-

In this setup, there is a toothed wheel having 20 teeth. When the motor runs at 1500 rpm (i.e. 25 revolutions/sec), the frequency of the pulse = $25 \times 20 = 500$ per second. i.e. when the motor runs at 1500 rpm, the pickup works as pulse generating transducer, producing 500 pulses per second. The circuit consists of 2 stages of AC amplification giving a very high overall gain. The resultant output is fed into a Schmitt trigger circuit using IC 555 Timer. The Schmitt trigger in turn triggers monostable, which generates constant width, constant height pulses. These shaped pulses are given to a panel meter for display through an additional amplifier.

A separate signal generator with a stable frequency of 500 Hz is provided for calibration. (Set the selector switch in magnetic pickup). When the output of this calibration source is connected to input of the amplifier stage and by using the potentiometer marked 'Max' the reading of the meter is adjusted to maximum speed of 1500 rpm. With this calibration, the panel meter (DPM) directly reads the speed of the motor in rpm.

Procedure:-

- 1) After calibration is done as given in the above section, set the selector Switch to the magnetic pickup side.
- 2) Connect the motor terminal cable to the output terminals of DC supply. Ensure that the dimmerstat knob is in zero position. Now switch on power supply for speed controller section and slowly go on changing the speed of the motor.
- 3) Note the speed in the panel meter.
- 4) Check the speed by using precision Tachometer.
- 5) Tabulate the readings as shown below.

Observations:-

S.No.	Tachometer Reading (T) Rpm	DPM Reading (M) rpm	$\% \text{ Error} = \frac{(T - M)}{T} * 100$

Graph:-

Draw the graph of Tachometer reading Vs DPM reading.

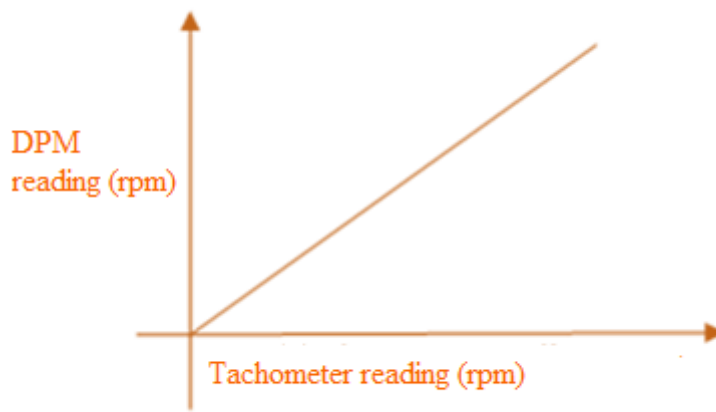
**Photo Electric Pickup:-**

This is another method of speed measurement of non-contact type based on photoelectric effect. The setup is designed to produce pulses proportional to the speed using phototransistor as sensing element. A disc with 20 holes is mounted on the motor shaft and when photo transistor and light source are properly aligned, every passage of hole across them produce a voltage pulse of high magnitude.

Circuit Operation:-

The electronic circuitry is same as magnetic pickup with an AC amplifier, Schmitt trigger and monostable circuits. When the motor is running at 1500 rpm, the photoelectric pickup circuit gives 500 pulses per second.

Calibration is to be done so as to give 1500 rpm in the panel meter at 'Max' position.

The procedure is same as done for 'magnetic pickup'

Procedure:-

1) After calibration is done as mentioned above, set the selected switch in the 'photo electric pickup' position.

2) Repeat the procedure as done in magnetic pickup after making proper connections to the motor.

Observations:-

S.No.	Tachometer Reading (T) rpm	DPM Reading (M) rpm	$\% \text{ Error} = \frac{(T - M)}{T} * 100$

Graph:-

Draw the graph of Tachometer reading Vs DPM reading.

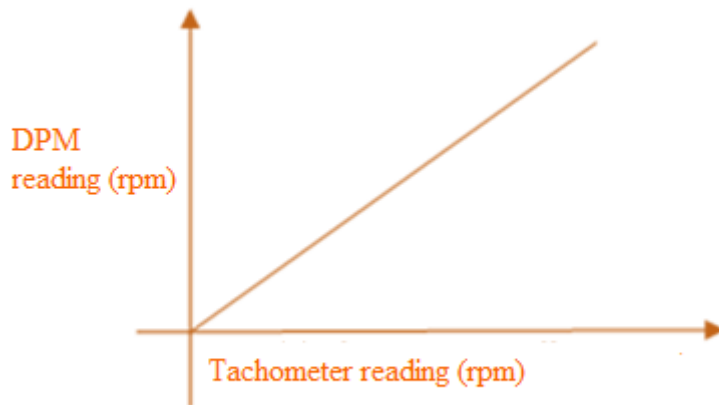

Result: - Speed of motor is measured by magnetic method and photoelectric method.

Discussion of result:-

The student will be able to discuss the different type of methods used for measurement of speed.

MEASUREMENT OF TEMPERATURE BY

A) THERMISTOR

Aim: - To study the characteristics of Thermistor for measuring temperature.

Apparatus required: - Electric heater, thermometer, Thermistor transducer and experimental setup.

Theory:-

Thermistors are semiconductors of ceramic materials, which are very sensitive to temperature. They have negative temperature coefficient (NTC). A typical Thermistor will exhibit a decrease in receptivity by a factor of 50:1 over a temperature of 0 to 100 °C maximum temperature may go up to 2000 °C.

Examples: Sintering oxides of metals such as Copper, Manganin, Nickel Cobalt, Iron etc.

Circuit Diagram:-

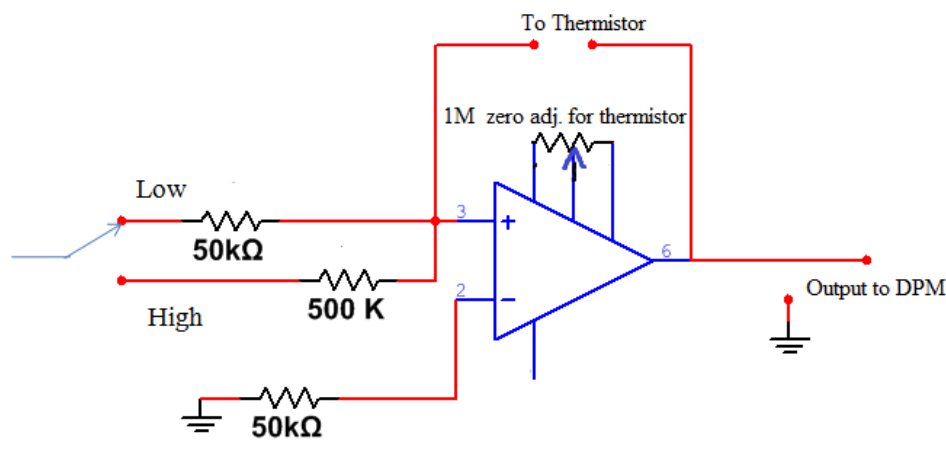

Figure: 1

Circuit Operation:-

Study of Thermistor characteristics

When thermistor is connected between the terminals 2 and 6 of Op-amp, with pin no 2 of Op amp at virtual ground, a fixed current of minus 0.1 milliamps (100 microamperes) will be flowing through the Thermistor because of 50 KΩ resistances and minus 5 volts supply.

Output pin 6 of the Op-amp will generate a potential which is exactly proportional to the resistance of the device under study. If thermistor resistance is 1999 ohms,

constant current of 0.1mA flowing through it will produce 199.9 mV which is directly measured on DPM.

Procedure:-

- 1) Connect the thermistor across the input terminals.
- 2) Connect the terminals marked “Output” to DPM input terminals.
- 3) Immerse thermistor in boiling water and note down the resistance of the transducer.
- 4) Switch off the heater supply and note the value of resistance for the temperatures read from thermometer.

Observations:-

S.No.	Thermometer Temperature (⁰ C)	Resistance of Thermistor (Ω)

Graph:-

Draw Resistance Vs Temperature.

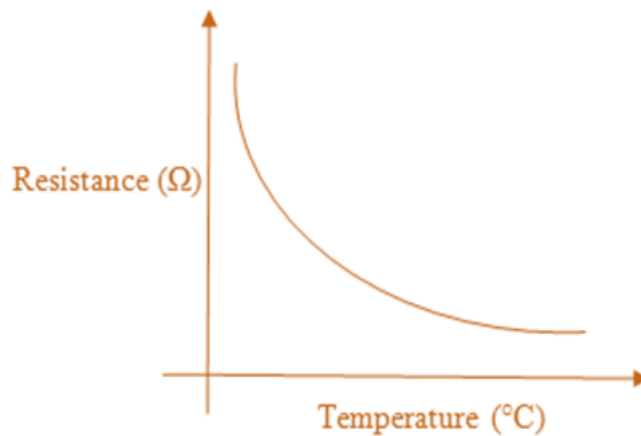

Result:-

Measured the different temperatures using thermistor and studied its characteristics.

MEASUREMENT OF TEMPERATURE BY

B) THERMOCOUPLE

Aim: - To study the characteristics of Thermocouple for measuring Temperature.

Apparatus required: - Electric heater, Thermometer, thermocouple experimental setup.

Theory:-

It is a transducer based on seebeck effect. Thermocouple is a self-generating transducer and basically a pair of dissimilar metallic conductors joined so as to produce an emf when the junctions are at different temperatures. Magnitude of emf depends upon the magnitude of temperature difference and materials of conductors.

Combinations of Copper-Constantan Iron-Constantan and Chromel-Alumel are examples.

Thermocouples are low in cost, reliable in service and easily used, cover wide range of temperature and good time response.

Circuit Diagram:-

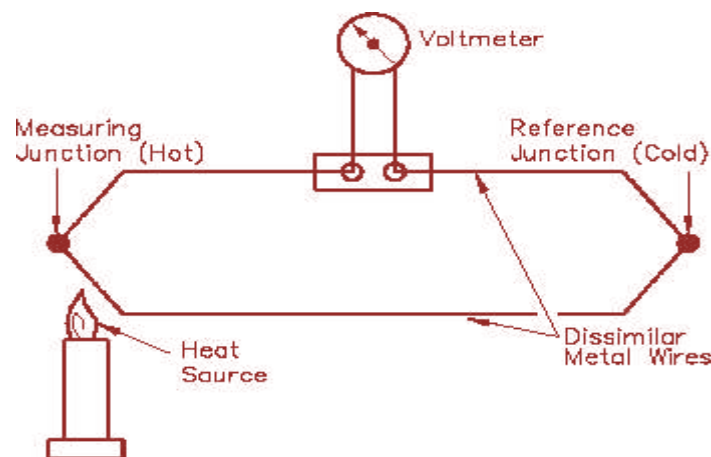

Figure: 1

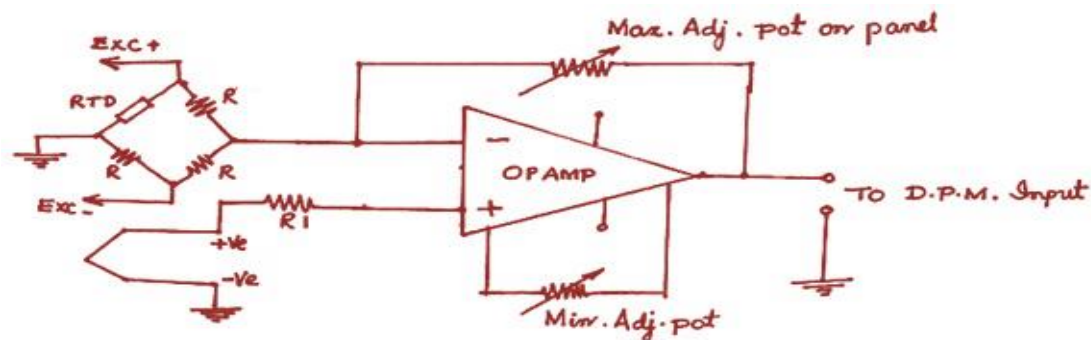

Figure: 2

Circuit Operation:-

The thermocouple output is connected to the non-inverting terminal of the Op-amp and gain of the amplifier is to be 20, when Max POT is in most clockwise position. To the inverting terminal of the Op-amp, output from a Wheatstone bridge is supplied. This bridge is excited from a highly stabilized dc supply of 6.5 volts using IC723 as a voltage regulator; the bridge excitation comes from a separate dc supply. As the ambient temperature goes on changing, the RTD's resistance also changes and the small output voltage is developed across the bridge. The bridge output is fed to the inverting input of the amplifier. With higher ambient temperature, the thermocouple transducer tends to produce lower output voltage. The RTD's bridge circuit automatically takes care of this tendency of thermocouple by applying a small voltage of proper polarity to the inverting terminal of the amplifier. The potentiometer "Max" on the panel is connected as a gain controlling feedback resistance and is useful for carrying out calibration operation. Potentiometer marked "Min" is useful for zero adjustment.

Procedure:-

- 1) Connect the thermocouple at the input terminals with proper polarity
- 2) Turn the "Max" POT fully to anticlockwise position.
- 3) Now switch on the heater supply. Connect output terminals of the thermocouple POT to the input terminals of DPM.
- 4) Immerse the thermocouple in water (at room temp.) and adjust the POT marked "Min" on the panel to get room temperature on the DPM.
- 5) When the water starts boiling the POT marked "Max" is adjusted to get the boiling point temperature (95°C). Repeat until you get satisfactory result.
- 6) Turn off the heater so that the water starts cooling down. Note the DPM reading and thermometer reading. Tabulate the readings as shown below

Observations:-

S.No.	Thermometer Reading (T) (°C)	Meter Reading (M) (DPM) (°C)	$\% \text{ Error} = \frac{(T - M)}{T} * 100$

Graph:-

Draw the graph of Thermometer reading Vs meter reading.

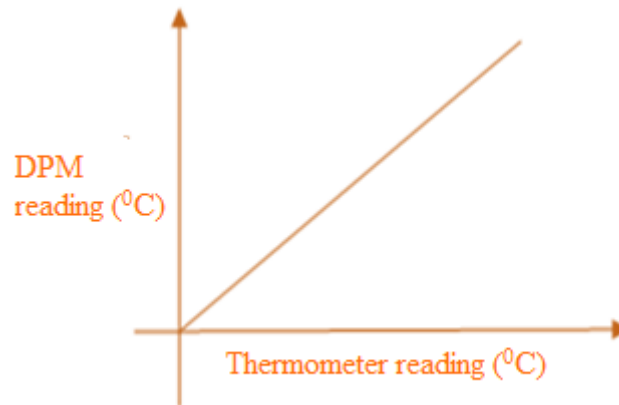

Result: - The temperature is measured using thermocouple.

Discussion of Result:-

The student will be able to

- 1) Discuss the sensitivity at low temperature measurement.
- 2) Discuss the nature of graph between measured temperature and resistance.
- 3) Calculate percentage error of thermocouple in comparison with thermometer reading.

STUDY AND CALIBRATION OF STRAIN GAUGE

Aim: - To study and calibrate the strain gauge.

Apparatus required: - Strain Gauge experimental setup, different weights.

Theory:-

Resistance strain gauges are transducers to sense the elongation or strain due to applied loads. The principle of operation depends on the fact that when a wire is stretched, its length and diameter changes. This results in overall change of resistance.

$$R = \frac{\rho L}{A}$$

Where R= resistance of wire

ρ = resistivity of material

L= length of wire

A= cross sectional area of wire

The main problem with the resistance wire strain gauge is the extremely small change in resistance as a result of change in the applied load. This makes the circuit operation and strain gauge installation very critical. Moreover temperature effects are also required to be taken care of.

Circuit Diagram:-

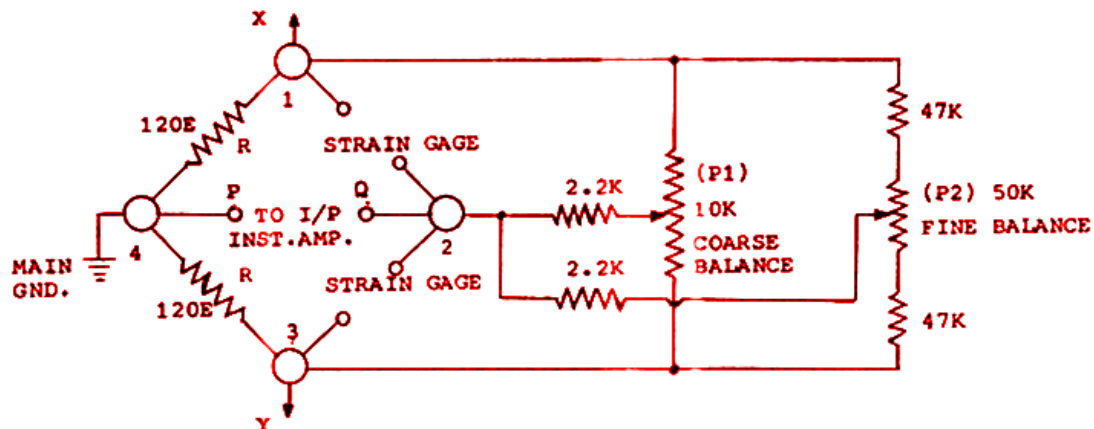

Figure: 1

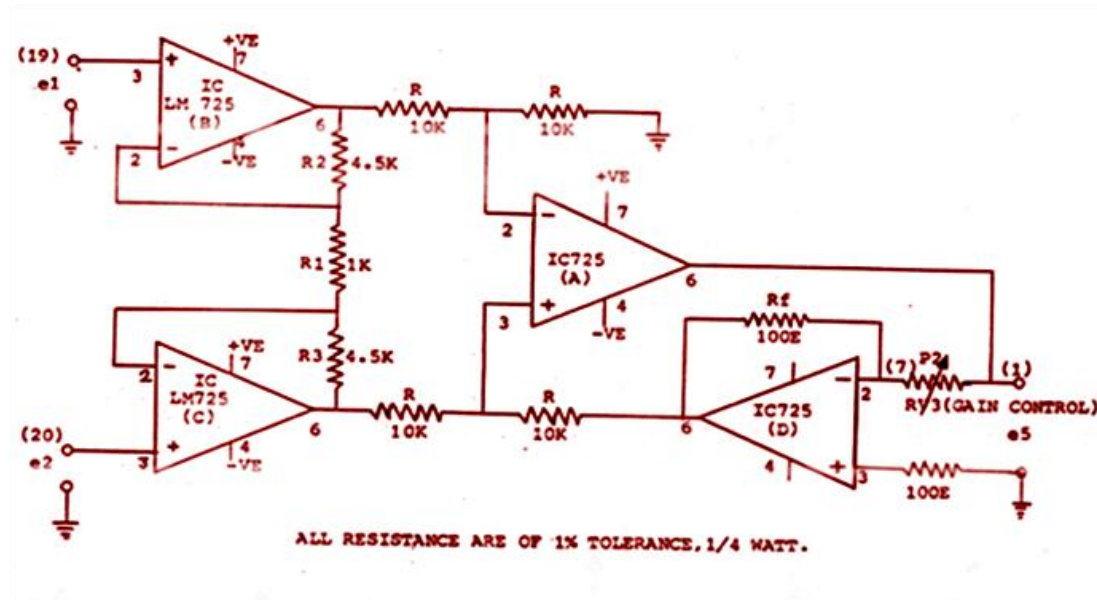

Figure: 2

Circuit Operation:-

On a mild steel bar, two single element Bakelite strain gauges ($R=350 \Omega$) are mounted with the help of adhesive cement on the upper surface and the two are mounted on the lower surface. When all the four gauges are used in the bridge we have a four arm system. If only two gauges (one from upper surface and one from lower surface) are used, we have a two arm system with two resistances of 350 ohms forming other two arms. The bridge is excited with the help of 5V supply using IC 7805. A 10 K Ω helical pot and 47 K Ω POT forms the coarse and fine balancing controls respectively.

The output of the bridge which is in the range of few hundreds of micro volts is amplified with the help of an instrumentation amplifier. Whose gain is adjusted by means of Amplifier adjust POT (10 K Ω). In maximum clockwise position, the gain of the amplifier is exactly 1000. The DPM used is 1.999 volt or 1999mV. Hence when the gain adjust pot is in maximum clockwise position the DPM reading exhibits directly the micro volts (neglecting the decimal points). The instrumentation amplifier is having low drift, high stable gain.

Procedure:-

Connect the flexible wires provided with the strain gauge cantilever beam between terminals 1-1, 2-2 and 3-3 (special care must be taken to ensure proper connection of terminal No 2). If terminals 1 and 3 are interchanged. Only the output polarity will be changed.

Amp gain POT might be in position of 200(note that 2.00*100 gives a gain of 200).

Turn on the main supply. By gently moving the balance POT P1 and P2, obtain initial balance on the meter and wait for 5 minutes to allow the strain gauge temperature to stabilize.

Now apply a gentle pressure by hand on the end of cantilever beam, the DPM should indicate some change in the readings. This indicates that strain gauge set up is ready for experimentation. Now keep P3 POT in maximum clockwise position of gain= 1000.Check for null balance again.

Now apply weights of 1Kg, 2Kg etc and note down the DPM reading (neglecting the decimal point). The DPM reading directly corresponds to number micro volts generated at the bridge output when the gain =1000. For lower value of gain say 500, the bridge output can be estimated with the help of DPM reading.

Perform calculations as indicated and compare with the meter reading.

Observations:-

S.No	Weight on the Cantilever (Kgs)	DPM Reading (Kgs)

Strain Gauge as a Load Cell:-

Apply a weight of 1kg on the cantilever and adjust the gain pot so that the reading of 1.00 is obtained on the DPM.

Now remove the weight and check for Bridge balance. After one or two such adjustments you will be able to get a reading of 1.00 on the DPM.

Here, we may note that least count of this arrangement becomes 0.01kg or 10gm.

Add weight up to 5kg and enter the results in the following table.

Specimens Calculations:-

1. For 2 arm bridge

$$E_{out} = \frac{Exc * \Delta R}{2R}$$

Where $\frac{\Delta R}{R} = Gf * strain,$ gauge factor $Gf = 2$

$$strain = \frac{stress}{y} = \frac{stress}{2*10^6}$$

and $stress = f = \frac{M}{z}$ where $z = \text{moment of cross section} = \frac{1}{6*b*t^2}$

b= width and t= thickness of cantilever beam, all dimensions in centimeters.

$$Z = \frac{1}{6*b*t^2} \quad \text{and } M = \text{applied load} * \text{length} = W * L = \text{Bending moment}$$

For example

If L= 17.5 cms, b= 2.55 cms and t = 0.565 cms

$$\text{Then } Z = \frac{1}{6*b*t^2} = \frac{1}{6*(3.142)*(0.565)^2} = 0.16616\text{cm}^3$$

Now if weight is 1 Kg then

$$M = W * L = 1\text{kg} * 17.5\text{cm} = 17.5 \text{ kg} - \text{cm}$$

$$\text{Therefore } f = \frac{M}{z} = \frac{17.5}{0.16616} = 105.315 \text{ kg/cm}^2$$

$$\text{This gives strain} = \frac{f}{y} = \frac{105.315}{2*10^6} = 52.65 * 10^{-6}$$

Assuming $Gf = 2$.

$$\frac{\Delta R}{R} = Gf * \text{strain} = 2*52.378*10^{-6} = 105.315$$

Hence

$$E_{out} = \frac{Exc * \Delta R}{2R} = \frac{5}{2} * 105.315 * 10^{-6} = 263.28 \mu V = 0.263\text{mV}$$

2. For 4 arm bridge

$$E = \frac{Exc * \Delta R}{R}$$

For same length, width and thickness of cantilever beam

$$z = \frac{1}{6 * b * t^2} = 0.16616\text{cm}^3$$

Now if weight is 1 Kg then

$$M = W * L = 1\text{kg} * 17.5\text{cm} = 17.5 \text{ kg} - \text{cm}$$

$$\text{Therefore } f = \frac{M}{z} = \frac{17.5}{0.16616} = 105.315 \text{ kg/cm}^2$$

$$\text{This gives strain} = \frac{f}{y} = \frac{105.315}{2*10^6} = 52.65 * 10^{-6}$$

Assuming $Gf = 2$.

$$\frac{\Delta R}{R} = Gf * \text{strain} = 2*52.65*10^{-6} = 105.315$$

Hence,

$$E = \frac{Exc * \Delta R}{R} = 5 * 105.315 = 526.575 \mu V = 0.526\text{mV}$$

Observations:-

S.No	Weight on the Cantilever (Kgs)	DPM Reading (mV)

Graph:-

Plot the graph of the applied load versus the experimental output.

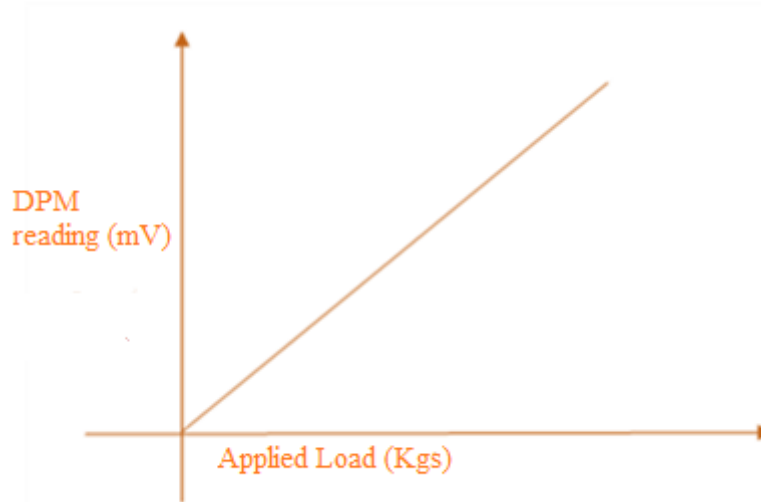

Result: - The known weights are measured by strain gauge and verified to be correct.

Discussion of Result:-

1. The student will be able to discuss the effect of dimensions of cantilever beam on output voltage.
2. The student will observe the differences in output voltage between 2 arm and 4 arm configuration used for measuring weights.

MEASUREMENT OF TORQUE

Aim: - To measure the torque of a rotating shaft.

Apparatus required: - Torque measurement setup.

Theory:-

The torque measurement relies on the principle that angular displacement of the shaft due to the applied torque (torsion) is directly proportional to it and also depends on its mechanical dimensions and properties of the material. The relationship is given by

$$\theta = \frac{0.36 * T * L}{3.14 * D^4 * G}$$

Where

G = Shear modulus of elasticity Kg/m².

θ = Angle of distortion in radians.

T = Torque in Kg-m.

L = Length of the shaft in meters.

D = Diameter of the shaft in meters.

Principle of Operation:-

The length of suitable shaft is mounted on the two ball bearings at both the ends. In between this length of torque sensors, two disks D₁ and D₂ with holes drilled on them are rigidly fitted on sensor shaft, keeping a distance 'L' between them. Twenty numbers (20) of holes with equal spacing are drilled on the disk.

When no torque is applied, both pulse trains are in phase with each other. Now, when load is applied, the load torque brings about a minute rotation of the disk D₂ (measuring disk) and to that extent the disk pulsed output from the photo sensor is also phase shifted with respect to that of disk D₁ (reference) .

The pulses generated from the disks D₁ and D₂ are individually wave shaped by passing through a buffer, amplifier, Schmitt trigger and finally a monostable circuit. The monostable circuit is a well defined pulse of constant width and height for each channel. These two pulses are operating on the set reset inputs of a flip flop, the rising edge of the pulse from D₁ channel will set a flip-flop while the rising edge pulse from D₂ channel will reset it, so that the output of the flip-flop will remain in high state for a time depending on the phase difference between the two pulses.

The frequency of pulses is proportional to RPM of the shaft and hence one of the disk output is further processed to get an indication of RPM also. Thus the setup enables the measurement of torque and speed.

The signal in terms of pulse train from channel D₂ is electronically processed to get a pulse of constant width and fixed height. These pulses when integrated gives an output which is proportional to the frequency of the pulses i.e. speed of the shaft. In order to check the calibration of speed, a standard and stable frequency of 500 Hz is internally generated which corresponds to 1500 rpm of the shaft speed. These functions are performed when the function switch is in speed mode.

Circuit Diagram:-

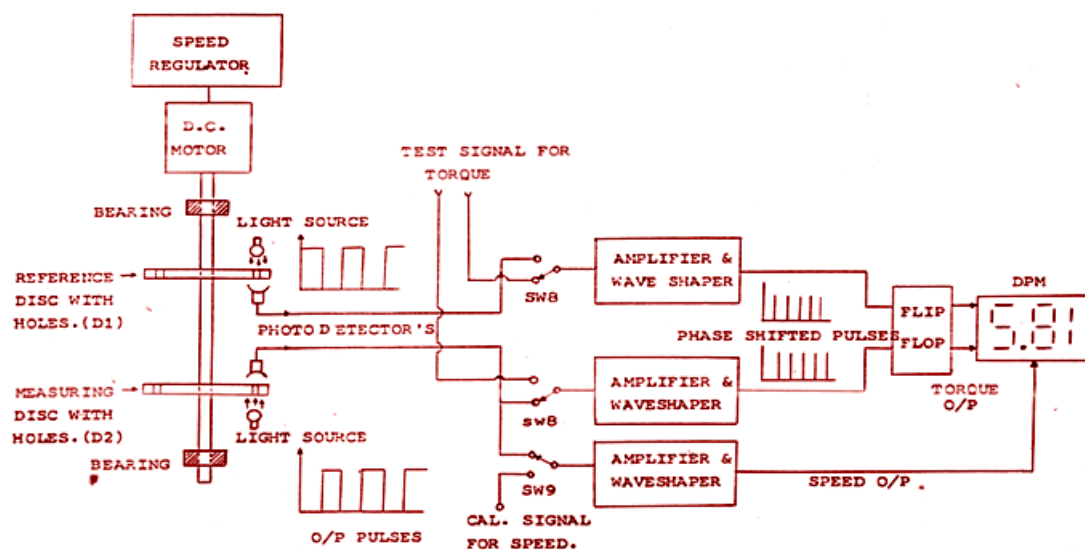

Procedure:-

- 1) Keep SW₈ in speed position, SW₉ in calibration position. The DPM should be 1500 RPM, confirming that speed circuit is in calibrated condition. Now keep SW₈ in right position, the DPM should indicate 180⁰ plus or minus, ensuring that electronic circuit is O.K. Now again take SW₈ in speed mode and SW₉ in Read position.
- 2) Switch ON speed controller and increase the speed of the motor slowly about 1500 RPM as indicated by the DPM.
- 3) Take SW₈ switch to Torque mode and torque should be indicated as 0.0 Kg-m.
- 4) If it is not zero, adjust Min POT to get zero condition.
- 5) Apply some load (5th hole in the loading rod).

Calculate the applied torque as $T = (T_1 - T_2) * R$

Where T_1 and T_2 are spring balance reading in kg.

R is the radius of the pulley in metre.

- 6) Adjust the Max POT to get calculated reading on the display of the DPM.
- 7) Again check the reading when no Load is applied.
- 8) Max and Min POTs should be adjusted to get consistent readings repeating steps 4 to 7 above (if necessary).
- 9) Now the set up is ready for experiment.
- 10) Load the motor for different loads changing the tensions in the spring balances and tabulate the readings.
- 11) By varying the speed another set can be taken.

Observations:-

S No.	T_1 (kg)	T_2 (kg)	$(T_1 - T_2)$	Calculated torque $T = (T_1 - T_2) * R$ in kg – cms	DPM reading Kg – cms

Graph:-

Plot the graph of calculated torque Vs DPM reading as shown in expected graph below.

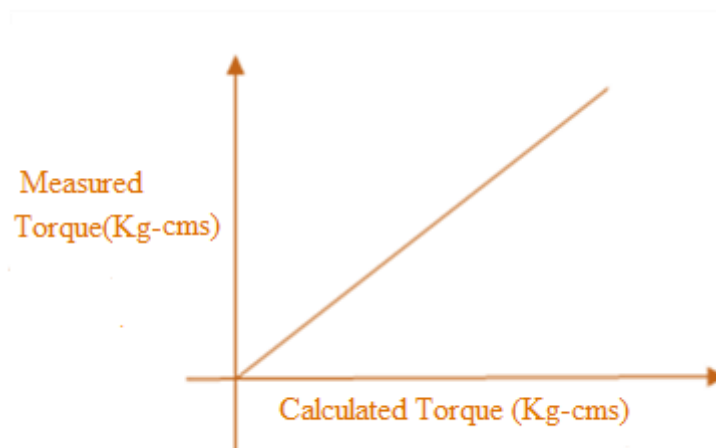

Precautions:-

- Do not keep the load continuously, as there is no cooling arrangement.
- The drum will be excessively hot and the rope will be damaged.

Result:-

The Torque is measured of rotating shaft is measured by applying different loads.

Discussion of Result:-

The student will be able to

- 1) Discuss torque developed by applying different loads.
- 2) Observe the effect of applied load and shaft dimensions on torque.

MEASUREMENT OF PRESSURE

Aim: - To study and calibrate pressure transducer using Piezo resistive element.

Apparatus required: - DPM, Pressure measurement experiment setup, Foot pump.

Theory:-

Pressure transducers can be classified into gravitational and elastic types. In the gravitational type, the familiar manometer is the simplest device. In elastic transducers, the pressure exerts a force over the area of an elastic device. The force responsive elastic member is in the form of a diaphragm, capsule, bellows or a bourdon tube. The resultant displacement is measured with an appropriate electric sensor. The most common type of pressure sensing element is the diaphragm. They are rugged, have excellent stability, reliability and low hysteresis.

Principle:-

The Motorola pressure sensor is designed utilizing a monolithic silicon piezo resistor, which generates a changing output voltage with variations in applied pressure. The resistive element, which constitutes a strain gauge, is diffused or ion implanted on a thin silicon diaphragm.

Applying pressure to the diaphragm, results in resistance change in the strain gauge, which in turn causes a change in the output voltage proportional to the applied pressure. The strain gauge is an integral of the silicon diaphragm. Hence there are no temperature effects due to differences in thermal expansion of the strain gauge and the diaphragm.

Circuit Diagram:-

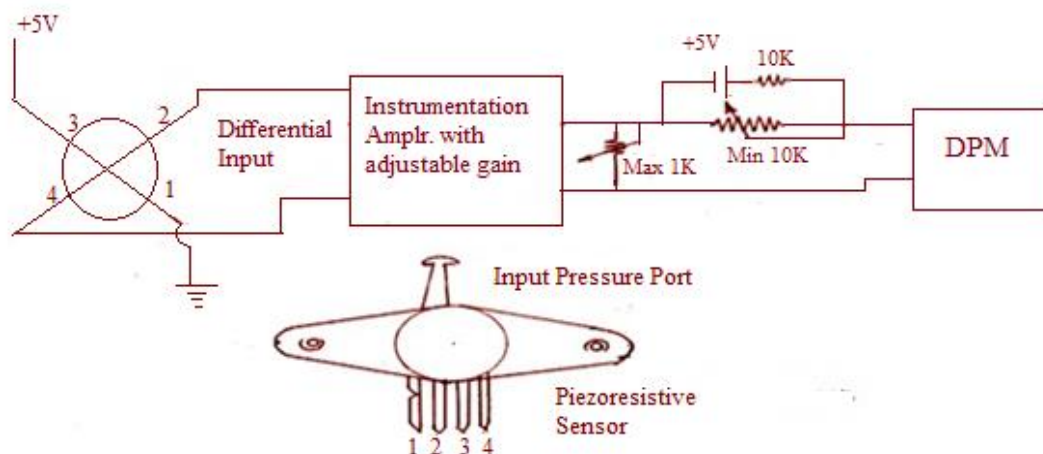

Description of the Apparatus:-

The top view of the pressure sensor chip shows the strain gauge resistor diagonally placed on the edge of the diaphragm to maximize shear stress and sensitivity to shear stress.

When the Pressure is applied normal to the plane of the diaphragm. Current is applied between the pins 1 and 3, while the taps that sense the voltage differential transversely across the pressure sensitive resistor are connected to pins 2 and 4.

The cross-sectional view illustrates the differential pressure sensing diaphragm which is also used for gauge pressure measurement. The difference diaphragm structure between a differential pressure sensor and absolute pressure sensor is that the latter does not have hole in the constraint wafer and the reference chamber contains a sealed in reference vacuum.

The cross-section of the differential diaphragm in its chip carrier package shows a silicon gel which isolates the diaphragm surface and wire bonds from harsh environments from a pressure signal to be transmitted to the silicon diaphragm.

Procedure:-

- 1) Establish the connection between pressure measurement set up and the main instrument by means of a cable.
- 2) For no pressure applied at the input, adjust POT marked 'Min' to get 0.00 indications on the DPM.
- 3) Now apply pressure to the input of the set by means of foot pressure provided. Get a maximum pressure of 15 psi on the pressure gauge and adjust the DPM indication using 'Max' to get a display of 15.00.
- 4) Now remove the foot pump connection. The pressure starts decreasing slowly because of inbuilt leakage. When pressure is decreasing, take the readings and tabulate the values.

Precautions:-

- 1) Min and Max values should be operated gently.
- 2) Do not apply pressure more than 15 psi.

Observations:-

S.No.	Input Pressure(A) psi	DPM Reading (E) psi	$\% Error = \frac{(A - E)}{A} * 100$

Graph:-

Plot the graph of applied input pressure versus output pressure on Dpm.

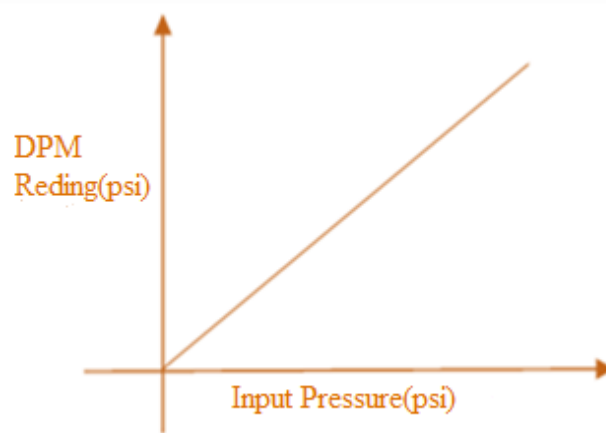

Result: - Pressure is measured using Piezoresistive sensor.

Discussion of Result:-

The student will be able to discuss the characteristics of pressure transducer.

MEASUREMENT OF DISPLACEMENT BY CAPACITIVE PICKUP

Aim: - To measure angular displacement using Capacitive transducer.

Apparatus: - Capacitive transducer, DPM.

Theory: -

Capacitance is function of effective area of the plates, separation between them, and the dielectric strength of the material between plates. If any of these parameters are changed, it causes change in capacitance.

$$C = \frac{(\epsilon_0 * \epsilon_r * A)}{d}$$

Where A = area of the plates.

d = distance between the plates

ϵ_0 = Permittivity of free space.

ϵ_r = Relative permittivity of the medium.

In this setup, the capacitor transducer works on the principle of variation of effective area of the plates, other parameters are kept constant. A two-ganged condenser is used here. The effective area between moving and stationary plates goes on changing as the shaft of the capacitor is rotated. This arrangement is used to demonstrate the measurement of the angular displacement.

Circuit Diagram:-

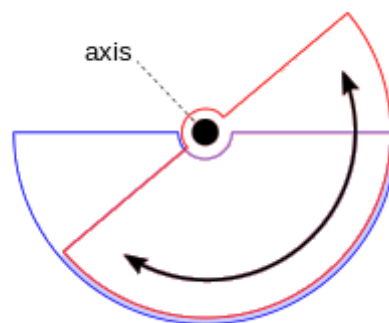

Figure: 1

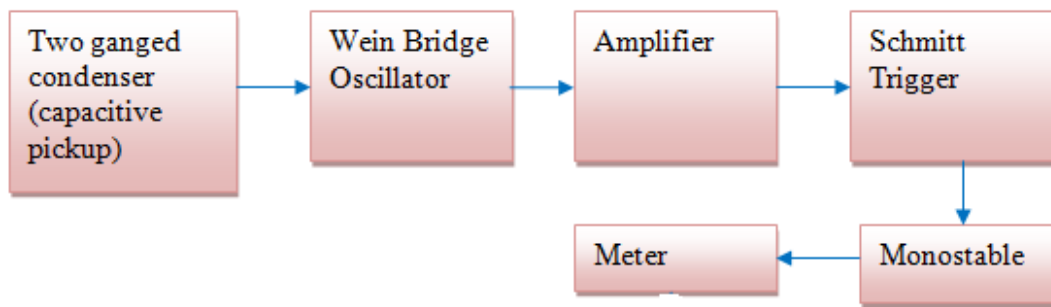

Figure: 2

Principle of Operation:-

The basis of the angular displacement measurement with the help of capacitive transducer is indicated in figure 1. The two sets of identical condenser form a part of the Wien Bridge oscillator for which the frequency is

$$F = \frac{1}{2.3 * 3.14 * RC}$$

(Assuming $R_1 = R_2 = R$ and $C_1 = C_2 = C$)

So if C is varied typically between (550 pF to 50 pF), we get the frequency variation in the range of 1: 10. On a separate PCB, signal generator and its allied circuitry is mounted. There is a buffer stage associated with this oscillator. The waveform is adjusted to be almost as a square wave. The amplification is done by IC741 and then fed to Schmitt trigger circuit using IC 555 timer. The output of Schmitt trigger is used to trigger the input of IC 555 monostable. The monostable output is of constant pulse width, constant pulse height, so that the meter reading is strictly proportional to the input frequency.

The output circuit is connected to a special bucking circuit, so that for zero angular displacement, the DPM reading can be adjusted to be zero. The necessary bucking voltage is obtained from a separate power supply. The pulse height is constant because of the use of a regulated power supply.

Procedure:-

- 1) Keep the input angular displacement to zero position.
- 2) Check for the zero indication on the DPM. Otherwise by operating potentiometer marked Min (P2) obtain zero indication.
- 3) Turn the shaft of the capacitive pickup to the fully clockwise position in a gentle manner corresponding to 170 degrees. Adjust DPM indication to 170 degrees by operating the knob marked Max (P1). Repeat the operation for consistent reading.

- 4) Note down the readings of input angular displacement and indicated angular displacement on the DPM.
- 5) Tabulate the readings as shown below.

Observations:-

S.No.	Input Angular Displacement in degrees	DPM Indication degrees

Graph:-

Plot the graph of input angular displacement on X –axis versus DPM reading on Y-axis.

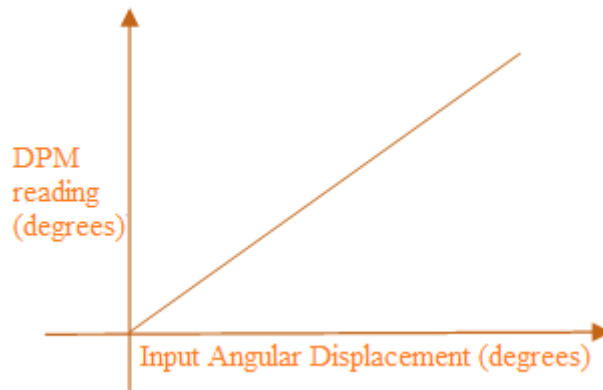

Result: - Angular displacement is measured using capacitive transducer.

Discussion of Result:-

The student will be able to discuss the change of capacitance by changing overlapping area between the plates.

MEASUREMENT OF DISPLACEMENT BY LIGHT

DEPENDENT RESISTOR

Aim: - To measure displacement using light dependent resistor.

Apparatus: - Light dependent resistor measurement setup.

Theory:-

If radiation falls upon a semiconductor, its conductivity increases. This is called photoconductive effect. This is the basis of operation for this experiment. Cadmium Sulphide Cell (CDS) has wide applications as a photo conductor. CDS photo conductors have dissipation capability, excellent sensitivity in the visible spectrum and low resistance. When simulated by light. In this set up LDR is used as displacement transducer.

Circuit Operation:-

The LDR is a variable resistance transducer. The change in the intensity of the incident light brings about a change in the resistance of the device. The LDR is connected across the feedback part of the of the Op amp CA 3140. The constant current coming from – 5 volts supply and fixed stable resistance of 500 K Ω passes through the photoconductive cell and depending on the value of the resistance produces an output in mill volts across the output of the Op amp and the ground terminal, in a proportional manner.

For shorted input terminals, the Min POT on the panel can be adjusted for zero indication and when the Max POT is in fully clockwise position, the DPM indicates the resistance of the photoconductive cell (Max 20 K Ω). If the front panel Max POT is kept in some intermediate position, the DPM only indicates some relationship between input and output.

Circuit Diagram:-

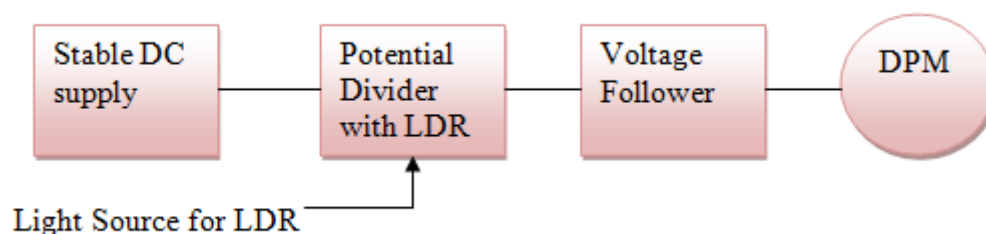

Figure: 1

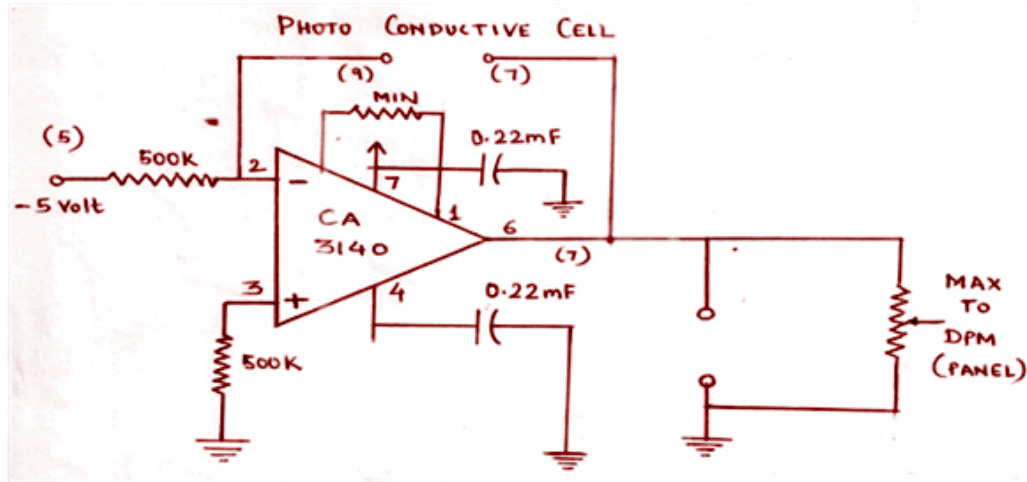

Figure: 2

Note: For Resistance of Photoconductive cell, the Max POT must be in the fully clockwise position.

Procedure:-

- 1) Connect the LDR to the input terminals on the front panel.
- 2) Connect the output terminals of the transducer circuit to the DPM, observing the polarity.
- 3) Adjust the channel to which LDR is mounted, so that full-scale deflection is obtained on the meter. If required use potentiometer marked Max on the panel.
- 4) Using the scale mounted on the bottom of C channel, measure the input displacement and the resultant DPM readings.
- 5) Tabulate the reading as show

Observations:-

S. No.	Effective Displacement (Input) cms	DPM Reading Resistance(in KΩ)

Graph:-

Draw the graph of input displacement versus the output resistance.

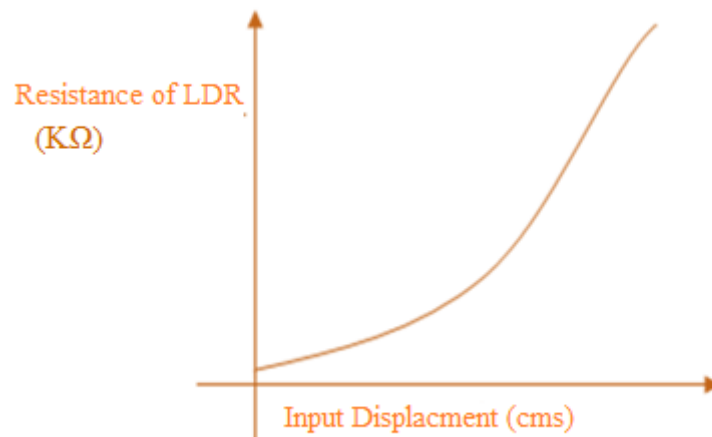
**Result:-**

Linear displacement is measured using LDR.

Discussion of Result:-

The student will be able to discuss the relation between input displacement and resistance of LDR.

LEVEL MEASURING SYSTEM

Aim: - To measure the water level in a tank.

Apparatus: - Level measuring setup DPM.

Theory: - Liquid level is an important variable in process plants. In many process industries, liquid in vessels such as mixers, fermenters, boilers is an indicator of the quantity and could be extremely significant for proper operation of the reactive process.

There are two types of Liquid level measurement.

- 1) Direct Method
- 2) Indirect Method.

In direct method, it is done by the reading graduations on any of the sight glass window, dip stick or gauge glass tube or use of float, reflection of sound or radar waves etc from the surface of the liquid.

Indirect method uses effect other than the location of the liquid surface above datum line.

- a) Measurement of Hydrostatic head or Pressure developed by liquid.
- b) Measurement of Buoyant force when float is fully or partially submerged.
- c) Measurement of conductance or capacitance of liquid, etc.

Description:-

In this set-up, water is liquid. At the bottom of M.S. tank, 6"x 6 " size a precision sensor with strain gauges on diaphragm is mounted. A gauge glass tube is fitted on the M.S. tank for measurement of water level.

Circuit Diagram:-

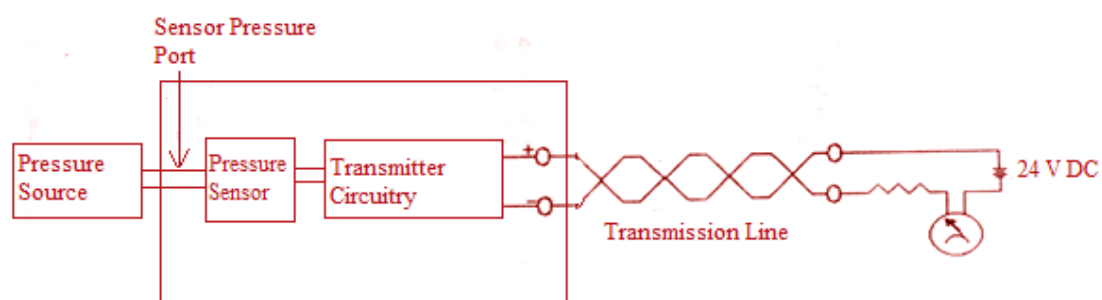

Figure: 1

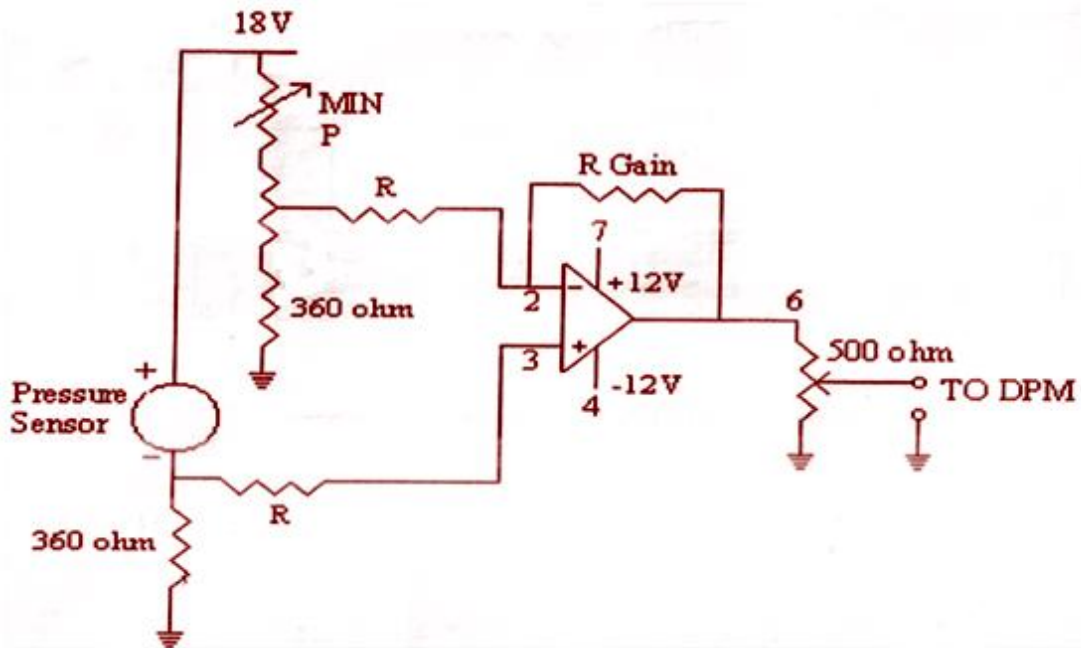

Figure: 2

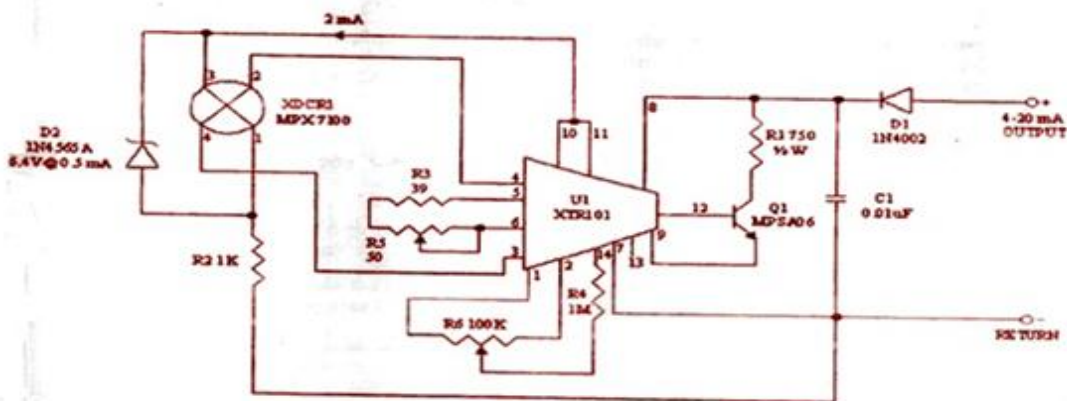

Figure: 3

Principle of Operation:-

The liquid column in a vessel exerts a pressure at the bottom surface of the vessel. The liquid height and the pressure are related by

$$h = \frac{p}{d} = \frac{p}{(pw * sgl)}$$

Where

h = height of the liquid in meters.

p = pressure in Kg/m³ or Kg/cm³.

d = density in Kg/m³ at the operating temperature.

pw = density of water at the same temperature.

sgl = specific gravity of liquid at operating temperature.

Pressure Sensor:-

Pressure sensor is designed to produce an output of 4 to 20 mA for a pressure range of 0 to 1 bar. It is used to convert the current signal into voltage signal using an Op-amp with calibration control Min and Max. The output voltage is generated by passing this 4 to 20 mA current through a fixed resistance of 360 Ohms.

The instrument produces direct read out for level in cms, when Min and Max POTs are adjusted properly. The current signal can be monitored when an ammeter (using DMM) is connected across the terminals marked as link or can be calculated from the voltage drop across a fixed resistance of 360 ohms, when switch SW₂ is in downward direction. In upward direction, the DPM indicates the level in cms directly.

Pressure Transducer: -

The two wire 4-20 mA current loop is one of the most widely utilized transmission signals for use with transducers in industrial applications. A two wire transmitter allows signal and power to be supplied on a single wire pair. The 4 mA minimum current in the loop is the maximum usable current to the power entire control circuitry.

Figure shows a block diagram of a typical 4-20 mA current loop system which illustrates a simple two chip solution for converting pressure to a 4-20 mA signal. This system is designed to be powered with a 12V to 24V dc power supply. Pressure is converted to a differential voltage by the sensor. The voltage signal proportional to the monitored pressure is then converted to the 4-20 mA current signals with the precision of two wire transmitters. The current signal can be monitored by a meter in series with the supply or by measuring the voltage drop across R₁.

A key advantage to this system is that circuit performance is not affected by a long transmission line. Change in water level brings about a change in pressure on the diaphragm of the pressure sensor. A differential output voltage produced as a result of pressure changes. This output voltage is applied to current transmitter internally.

The XTR 101 current transmitter provides two one-mA current sources for sensor excitation when its bias voltage is between 12V and 40V. The pressure sensors are constant voltage devices, so a zener D₂ is placed in parallel with the sensor input terminals. The offset adjustment is composed of R₄ and R₆. They are used to remove the offset voltages at the differential inputs to XTR 101. R₆ is set so a zero input pressure will result in the desired output of 4mA. R₃ and R₅ are used to provide the full scale current span of 16mA. R₅ is set such that 1 bar (1 Kg/ cm²) input pressure results in the desired output of 20 mA.

Procedure:-

1. Keep the level tank on a suitable stool with bucket below the ½"cock provided on the tank.
2. Connect the 5 pin Amphenol cable to the socket on the instrument. With SW₂ in upward (level) position, switch on the supply & give a warm up time above 10 minutes for the system to stabilize. Ensure that a link is in place across the terminals, marked link on the rear panel.
3. With valve close, pour water from the top into the tank so that datum level of 5 cm is reached.
4. Adjust Min POT (P2) so that water level is indicated as 5.0 cm on DPM. Now pour water into the tank carefully so that a level of 60 cm is reached.
5. Adjust the reading on DPM by max POT P1, so that DPM reading is 60.0 cm.
6. Repeat steps 3 & 4 alternately so that you get proper readings at 5.0 cm and at 60.0 cm level.
7. Now you can check calibration at intermediate points. Start from 60 cm level & enter the results in tabular form. While taking readings, you may note that when switch SW₂ is in downward position, DPM indicates the voltage in mV, produced by sensor current which is in the range of 4 to 20 mA for a pressure range of 0-1 Kg/cm² (i.e for 10 meters of water head), thus current flows through a resistance of 360 ohms, which in turn produces a voltage drop of 360 x 4 mA = 1440 mV. Thus the current signal is changed into voltage for further processing before indication. You may also measure current directly by inserting DMM in current range of 0-20 mA for measurement purpose. In case ammeter is not used, a shorting link is a must.

Observations:-

S.No	Input Reading (Cms)	DPM Reading (Cms)

Graph: - Plot the graph of scale reading and DPM reading.

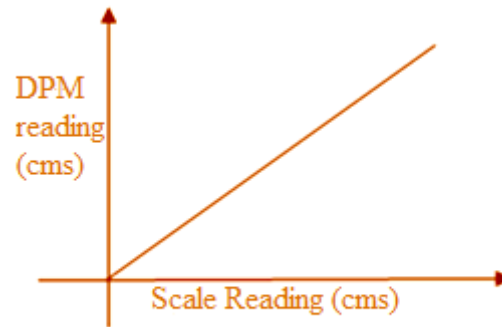

Result: - The liquid level is measured using pressure transducer.

Discussion of Result:-

The student will be able to discuss the relation between liquid level and the pressure exerted by liquid.

STUDY AND CALIBRATION OF LVDT

Aim: - To study and calibrate Linear Variable Differential Transformer (LVDT).

Apparatus required: - LVDT setup, DPM.

Theory:-

One of the most variable inductive transducer is the differential transformer, which provides an ac voltage proportional to the displacement of the core passing through the windings. It is a mutual inductance device making use of three coils arranged generally on a single cylindrical concentric non-magnetic former. The control coil (primary) is energized from an external power source and the two end coils (secondary) connected in series opposition to each other, are used as a pickup coils. Output amplitude and phase depends on the relative coupling between the two secondary coils and the primary coil. Relative coupling between them is dependent on the position of the core. At null position the resultant voltage $E_0 = E_1 - E_2 = 0$ as $E_1 = E_2$. Within the limits on either side of the null position, the output voltage magnitudes are ideally the same for equal core displacement the phase relation existing between power source and output changes 180° through null. It is therefore possible through phase sensitive detector to distinguish between outputs resulting from either side of null.

LVDT is a very widely used transducer for conversion of mechanical displacement into proportional electrical voltage, range from few microns to few tens of inches. It is free from temperature effects.

Circuit Diagram:-

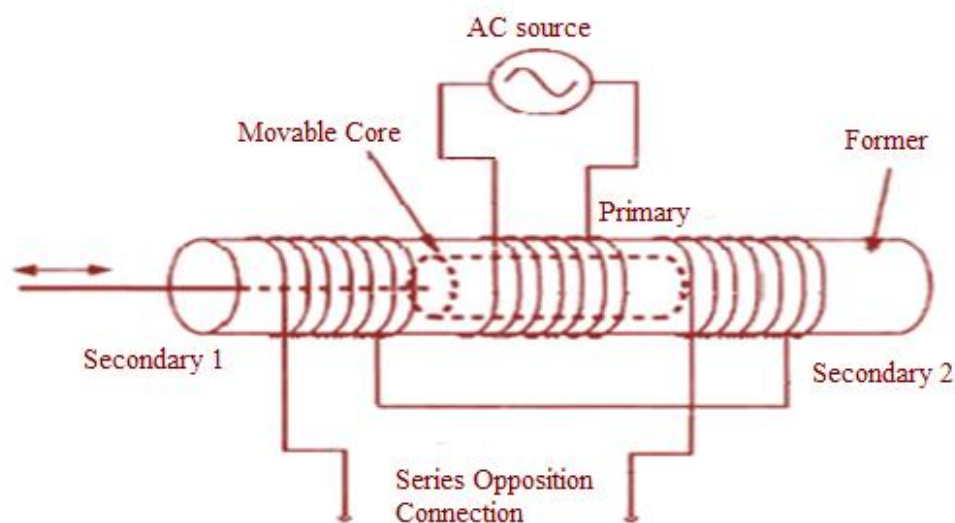

Figure: 1

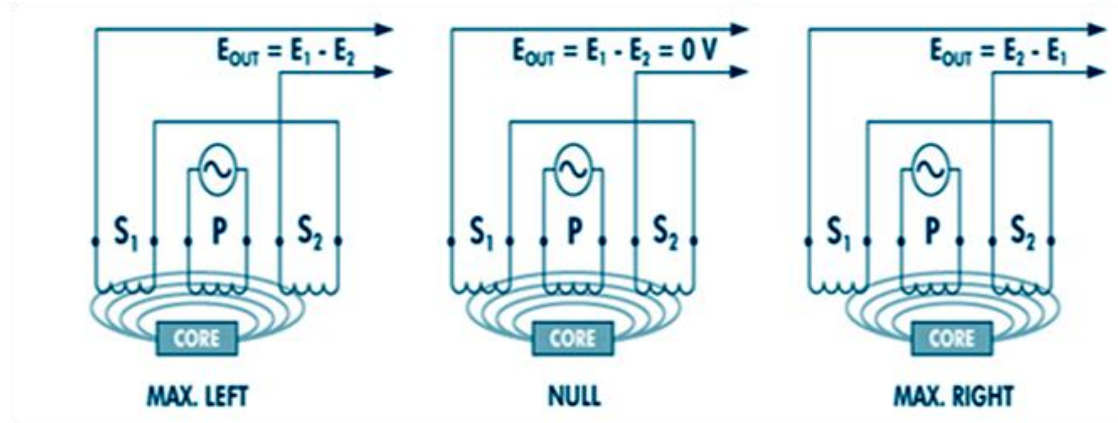

Figure: 2

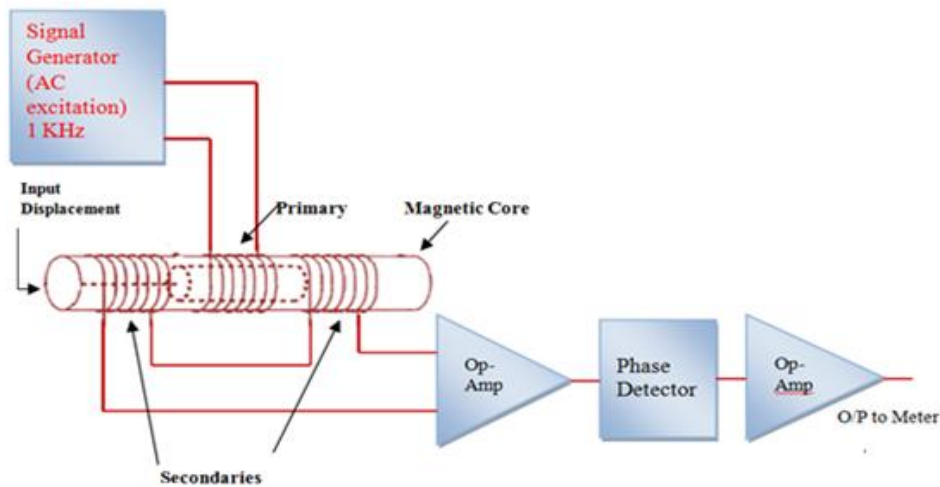

Figure: 3

Circuit Operation:-

The primary winding of LVDT is excited by means of 4 KHz power source. The Wein bridge oscillator circuit placed on a separate PCB generates a stable ac excitation of 4 KHz. The output from signal generator card is given to complimentary power transistors namely AD161 and AD162. The power amplifier in turn provides excitation to primary winding of LVDT.

The output from secondary is amplified by means of an Op-amp741(IC-D).The POT marked 'Max' on the front panel controls the value of feedback resistance and in turn gain of the amplifier. Separate Op-amp318(IC-B) converts the excitation signal into square waves which serve to provide reference signal for phase sensitive detection.

A field effect transistor 2N3819 acts as an analog switch and a phase detected output is generated. The output from the first stage amplification(IC-D) is passed through an all pass network (consisting of IC-C) which facilitates proper phase adjustment with the help of preset PR1. The output from this all pass filter is given to the phase

sensitive detector circuit. The PR1 is factory adjusted. When output of secondary and reference signal are in phase, dc output offset say positive polarity is generated and vice-versa. The magnitude of dc output is also proportional to the amount of displacement of the core. Thus both direction and magnitude of core displacement are detected. Finally the output of PSD is passed through a voltage follower (IC-A) before providing input to the DPM. The functioning of panel sensitive detector is better understood by observing the waveform provided along with circuit diagram.

Procedure:-

- 1) Connect the terminal marked ‘primary’ on front panel of the instrument to the terminals marked ‘primary’ on the transducer itself, with the help of flexible wires provided along with the transducer.
- 2) Identically establish connections from terminals marked ‘secondary’.
- 3) Keep POT marked “Max’ in the most anti-clockwise position.
- 4) The magnitude core may be displaced and the pointer may be brought to zero position. If the DPM is not indicating zero, use potentiometer marked ‘Min’ to get zero on DPM at zero mechanical position. If the core is displaced in the both directions the meter must show the indication with appropriate polarity. Now displace the core to 20mm position in one of the directions. Adjust the ‘Max’ to get an indication of 1.999 on the DPM under this condition. Now the setup is ready for experimentation. You may again check for zero position also.
- 5) Now the core can be displaced by known amount in the range of +20 and -20 mm and the meter readings can be entered in the table given below.
- 6) It may be noted that by interchanging the secondary terminals or the primary terminals the polarity of the meter indication can be reversed for a given direction of input displacement.

Observations:-

S.No.	Input Displacement +X Axis mm	Meter Reading (DPM) mV	Input Displacement -X axis mm	Meter Reading (DPM) mV

Graph:-

Plot the graph of input displacement and the output indications (meter reading) on X and Y axis respectively.

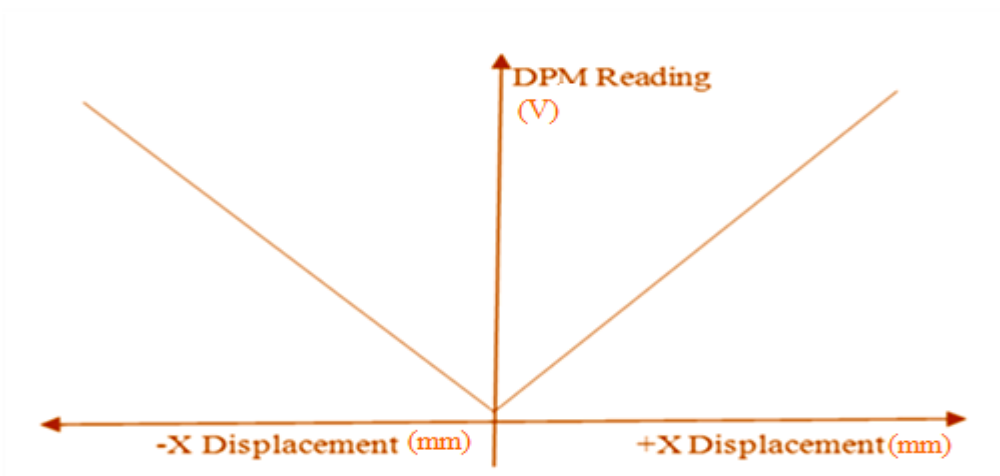

Result: - Linear displacement is measured by linear variable differential transformer.

Discussion of Result:-

The student will be able to discuss

1. The nature of graph between input displacement and output voltage.
3. The residual voltage.

STUDY AND CALIBRATION OF RTD

Aim: - To study the characteristics of Resistance Temperature Detector for measuring temperature.

Apparatus required: - Electric heater, Thermometer, RTD transducer and experimental setup.

Theory:-

The principle of operation of RTD is based on the fact that the electrical resistance of a metal increases directly with the temperature and is reproducible to high degree of accuracy.

$$R_t = R_0(1 + \alpha t)$$

Where α is temperature co-efficient of resistance of the metal.

R_t is the resistance of the element at temperature t .

R_0 is the resistance of the element at 0°C .

t is the temperature of the element in $^\circ\text{C}$.

Circuit Diagram:-

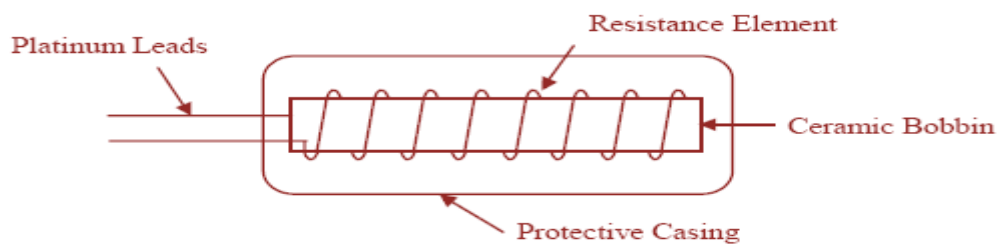

Figure: 1

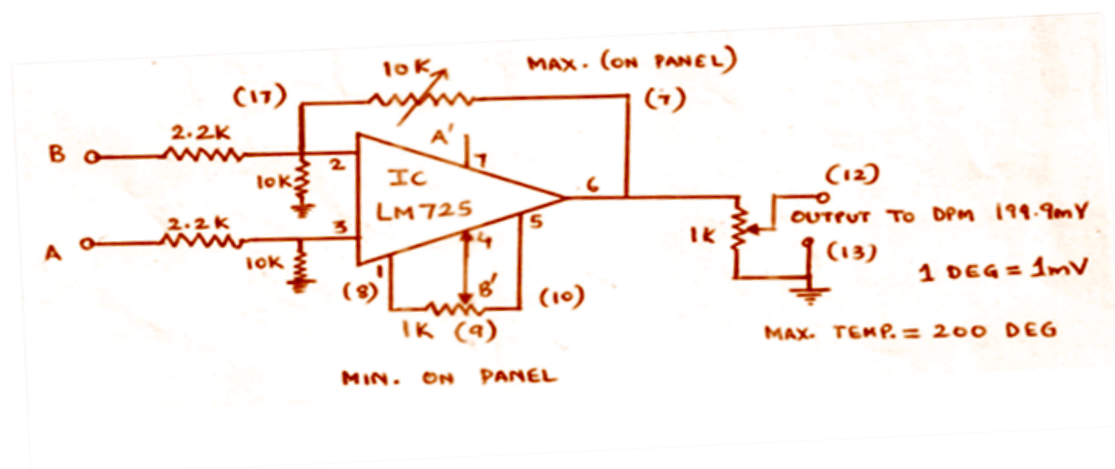

Figure: 2

PART –I --- Study of RTD Characteristics

Procedure:-

- 1) Immerse RTD in boiling water and note the resistance on the panel meter.
- 2) Switch off the heater supply and note the values of resistance for various temperatures using thermometer.
- 3) Tabulate the readings as follows.

Observations:-

S.No.	Bath Temperature (in $^{\circ}\text{C}$)	Resistance Reading (in Ω)

Graph:-

Draw the graph between measured temperature and output resistance.

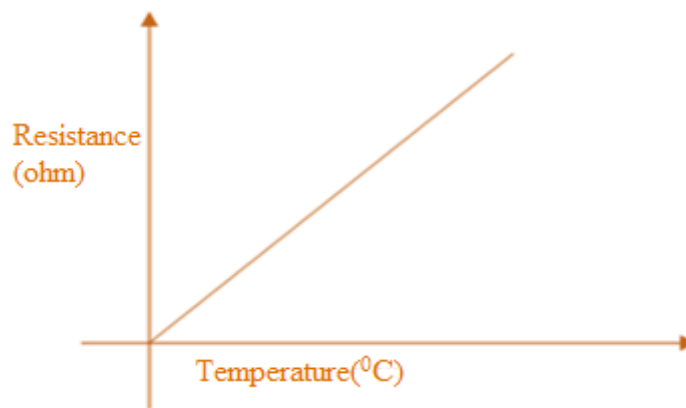

PART II --- RTD used as Temperature Indicator.

Circuit Diagram:-

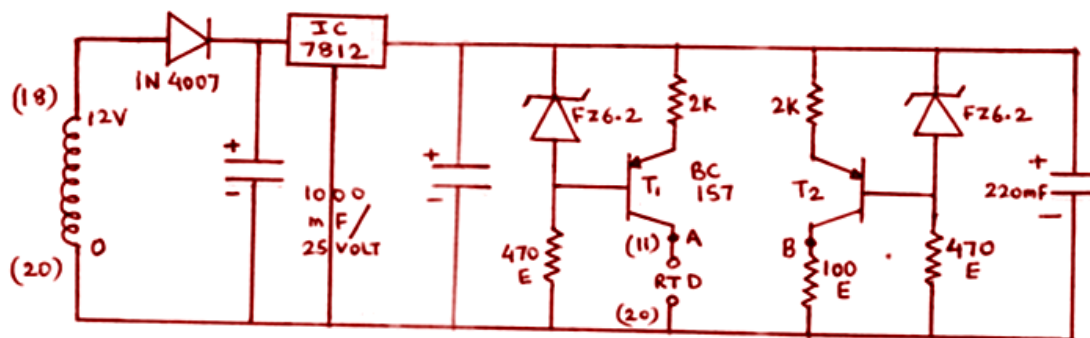

Figure: 3

Circuit Operation:-

When RTD is connected in series with the collector of transistor T_1 , transistor T_1 and T_2 are working as constant current sources. When RTD is at 0°C , the resistance of RTD is $100\ \Omega$. Under this condition, point A and B are at equipotential wrt point C. Hence the output of Op-Amp (ICLM 725) is at 0 levels. When resistance of RTD changes (as a result of temperature change), V changes proportional to resistance because a constant current is flowing through the RTD. This voltage is amplified and the output is displayed on DPM.

Procedure:-

- 1) Keep the switch SW_2 in position marked "Temp".
- 2) Connect precision resistance of $100\ \Omega$ across input terminals.
- 3) Adjust POT marked minimum to read "0" on DPM.
- 4) Now connect the precision resistance of $139\ \Omega$. Adjust maximum POT to read 100 on DPM. Note that resistance of Pt 100 is $100\ \Omega$ at 0°C and $139\ \Omega$ at 100°C .
- 5) Connect RTD across input terminals and measure unknown temperature in the range $0\text{-}200^\circ\text{C}$. Using heater and water bath various temperatures can be obtained.
- 6) Tabulate the DPM Reading and Thermometer reading.

Observations:-

S. No.	Thermometer Reading(T) $^\circ\text{C}$	DPM Reading(M) $^\circ\text{C}$	$\% \text{ Error} = \frac{(T - M)}{T} * 100$

Graph: - Draw graph between thermometer and DPM reading.

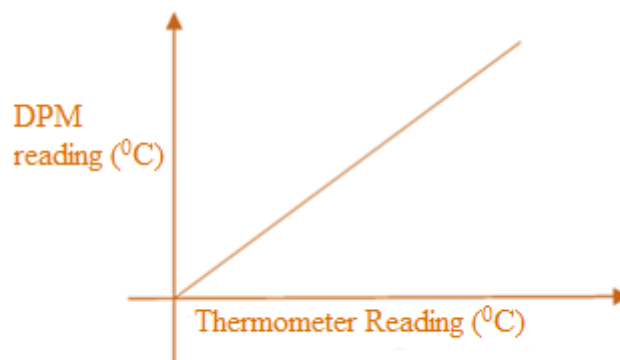

Result: - Temperature is measured by thermometer and verified by RTD.

Discussion of Result:-

The student will be able to

1. Discuss the nature of RTD sensor.
2. Calculate percentage error of RTD in comparison with thermometer reading.
3. Discuss linear relation between input temperature and output resistance of RTD.

MEASUREMENT OF DISPLACEMENT BY INDUCTIVE PICKUP

Aim: To measure displacement using inductive transducer.

Apparatus: - Inductive Pickup setup.

Theory: An electric circuit inductance indicates the magnitude of flux linkages in the circuit due to current. The inductance is determined by the number of turns, geometrical configuration and effective permeability. The variation in any one of these usually caused by displacement, alters the Inductance L .

The inductive transducers are useful for non-contact type displacement measurement problems. However unless they are operated on differential mode; they exhibit lot of non-linearity between input and output. They are low impedance transducers.

Circuit Diagram:-

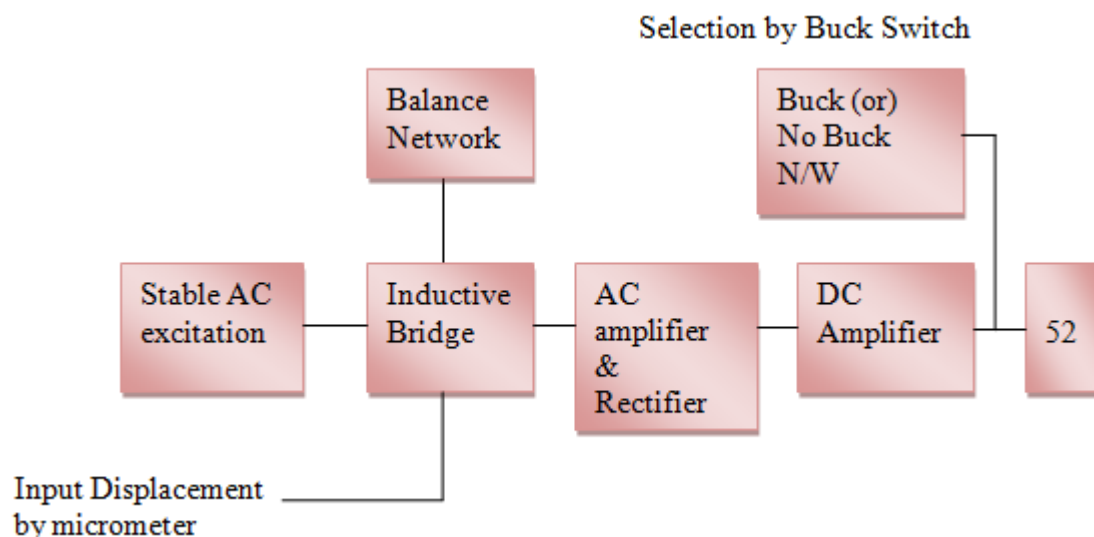

Figure: 1

Circuit operation:

The transducer in this set up is operating on the principle of variation of permeability or reluctance of the magnetic circuit. The inductive coil is mounted on a micrometer and as the steel bar of the micrometer moves in or out of the core of the coil, the inductance increases or decreases accordingly. When a simple single coil is used as a transducer element, the input usually changes the permeance of the flux path generated by the coil, merely changing the inductance.

The inductive pickup has three distinct sections.

1. Bridge network.
2. Excitation source.
3. Bridge output amplifier and final indication (and bucking source).

Excitation Source:

A sinusoidal excitation of 1 KHz is obtained by making use of 741 Op-amps in Wein bridge oscillator circuit. This output is given to a voltage follower stage and an amplifier before it is fed to the inductive bridge circuit.

Bridge Network:

The output of the excitation source is impressed across the primary of the transformer and the secondary of it excites the inductive pickup. Two arms of the inductive bridge are resistive and other two are inductive in nature. The coil mounted on the micrometer works as a variable inductance element and there is dummy inductance very close to isolating transformer inside the main instrument. The resistance is made variable and is used to make Zero or Min adjustment.

Amplifier:

The output of the bridge is rectified and then filtered. The filtered output is further amplified and connected to the DPM. The variable resistance marked Max is working as POT and its output is given to DPM for final indication. For differential measurements, additional bucking source is included.

PART-1 (Without Bucking Circuit)**Procedure:**

1. Keep the micrometer circuit reading at 25 mm position.
2. Connect the output of the amplifier to the DPM input. Keep SW₁ in the upward position. Keep the Max POT in the mid position. Now adjust Min POT carefully to get minimum reading on the DPM.
3. Now move the magnetic core gently away from the coil to position 35 mm and adjust indication of 011 mill volts on the DPM corresponding to a displacement of 10 mm with the help of Max POT (indicating a resolution of 0.1mm). Now check back for minimum reading at 25 mm position.
4. Enter the readings in the table as shown.

Observations:

S.No.	Effective input Displacement mm	DPM reading mm

Graph: Plot the graph between input displacement versus output reading.

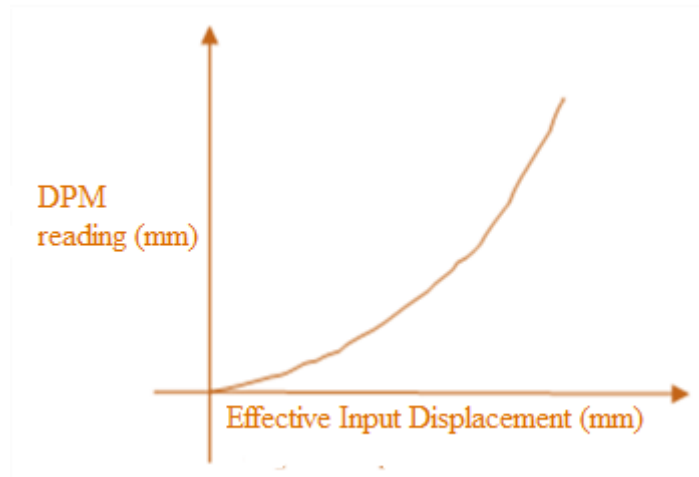

Part-II (Using the Bucking Circuit)

Circuit Diagram:

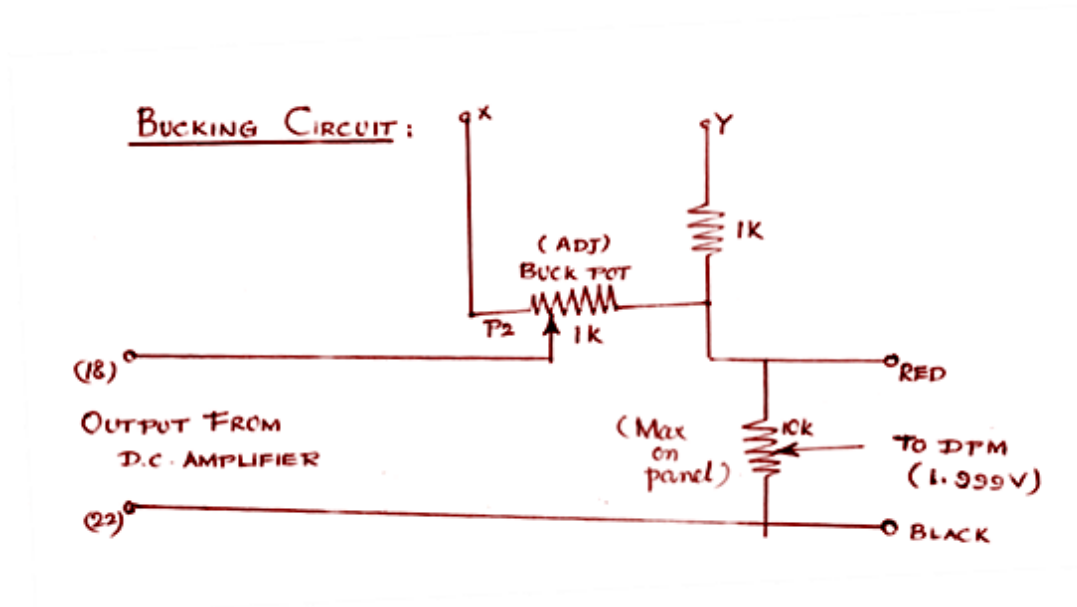

Figure: 2

Procedure:

1. Repeat 1 and 2 as per the previous part of the experiment.
2. Now keep SW_1 to downward position (Buck Position) and move the core to 30 mm position.
3. Now adjust pot marked "Buck" to get zero output. Slightly disturb the Min POT also if necessary. Now take the core to 35 mm position and adjust the Max POT to get a reading of 50. Take the readings for various core positions and tabulate the readings as shown.

Observations:

S.No	Effective input Displacement (mm)	DPM Reading (mm)

Graph: Plot the graph between input displacement and DPM reading.

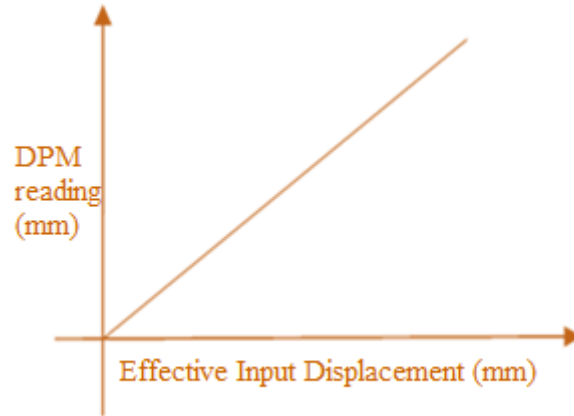

Result: - Linear displacement is measured using Inductive transducer.

Discussion of Result:-

The student will be able to discuss

1. The relation between input and output with and without bucking circuits.
2. The type of inductance used for measurement of linear displacement.